

Data Sheet

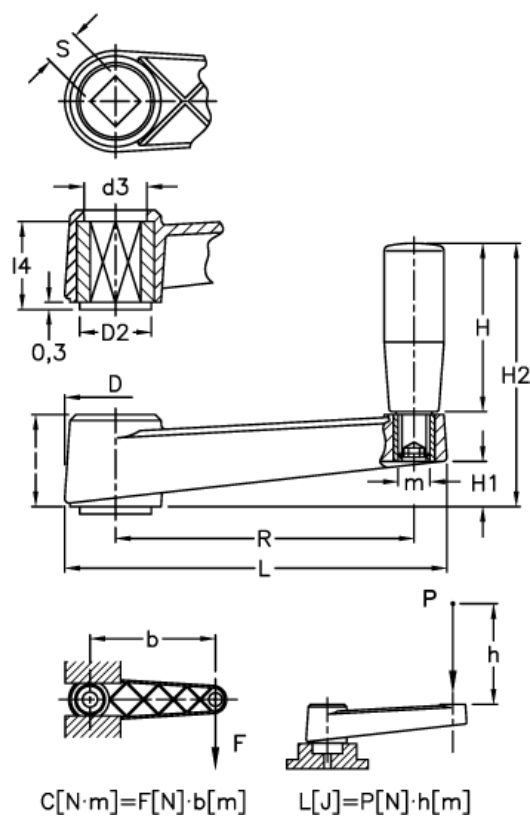

Article number: 2301044511
Description: E+G Crank handle
MT.160 AS-17x17

Measures



C (N m) = 450	L = 198
D = 45	L(J) = 55
d2 = 30	l4 = 34
d3 = 27	m = M10
H = 90	R = 160
H1 = 23	S H9 = 17x17
H2 = 130	
l = 40	